

Table of Contents

Item #	Page #	Item #	Page #	Item #	Page #	Item #	Page #
10100	3	10610	10	50109	36	70102	19
10101	3	10611	10	50110	37	70103	19
10102	4	10625	10	50112	35	70130	23
10103	5	10626	10	50113	36	70131	24
10104	5	10901	10	50114	36	70132	23
10105	5	10902	10	50115	36	70135	24
10106	7	10920	31	50117	35	70140	26
10108	7	12105	32	50120	37	70150	19
10109	4	12107	32	50121	37	70160	6
10300	11	12109	32	50122	38	70200	34
10301	6	12112	32	50130	37	70201	34
10302	6	12113	32	50140	38	70210	39
10303	6	12119	32	50146	40	70211	39
10304	6	12122	32	50147	38	70212	39
10305	6	12123	32	50150	40	70215	26
10306	6	12500	11	50155	40	70220	39
10308	11	12501	11	50200	27	70221	34
10309	6	12502	11	50301	27	70222	34
10312	11	12503	11	50303	27	70223	34
10400	18	12505	12	60100	28	70225	26
10402	17	12510	12	60101	28	70300	20
10403	18	20100	21	60102	28	70301	20
10405	17	20101	21	60104	28	70301	20
10414	15	20200	21	60105	28	70901	34
10424	15	20202	21	60106	28	70902	34
10431	22	20204	21	60107	28	70903	34
10435	33	20380	21	60108	28	70904	34
10436	33	20450	20	60202	25	80100	29
10437	33	20451	20	60203	25	80101	29
10439	15	20452	20	60300	22	80200	29
10451	16	20453	20	60301	22	80204	29
10452	16	20454	20	60302	22	80206	29
10465	16	20455	20	60303	22	80212	29
10500	8	30100	42	60500	25	80214	29
10502	9	30120	41	60501	25	80217	29
10508	9	30125	41	60502	25	80219	29
10509	14	30135	41	60503	25	80220	29
10513	14	40100	30	60504	25	80221	29
10515	14	40105	30	60505	25	80222	29
10522	14	40106	30	60506	25	90100	13
10590	8	40107	30	60507	25	90200	13
10592	8	40110	30	60508	25	90300	13
10594	9	40112	30	60509	25	90350	12
10600	10	40121	30	60800	31	90401	14
10603	10	40320	29	60801	31	90402	14
10604	10	50100	28	60925	40	90403	14
10605	10	50103	35	60929	28		
10606	10	50107	35	70100	19		
10607	3	50108	35	70101	19		



Giant Tire/Earth Mover Bead Breaker



10209 Kit In Use

- Use on 5-piece rims 25" to 51" with pry bar/bead loosening pockets.
- 4-1/4" stroke, 13.8 ton ram will break the toughest beads.
- Same as IMT-1800.
- 10207 kit contains 10100 bead breaker, 10500 pump and 10604 hose assembly.
- 10209 kit contains 10100 bead breaker, 10592 pump and 10604 hose assembly.
- Use with any 10,000 p.s.i pump.



10100



- Model 10607 is for use on Caterpillar vehicles with modified Shur-Lok rims.
- Allows bead breaker to be tightened against a flat surface.
- Fits all style earth mover bead breakers, except 10104 (Goodyear TO-100)



10607

"Combi" Bead Breaker



10101

- Works on single, two and three-piece truck tires/ rims, including some new style wheels.
- Breaks beads in seconds using 10,000 lbs. of force.
- The "Combi" Bead Breaker will not work on five-piece earth mover giant wheel/rim. Model 10100 or 10105 required.
- Similar to IMT-210 but has patented side straps which allow tool to be used on newer high flanged wheels.
- The 10200 kit contains 10101 bead breaker, 10500 pump and 10604 hose.
- The 10202 kit contains 10101 bead breaker, 10592 pump and 10604 hose assembly.

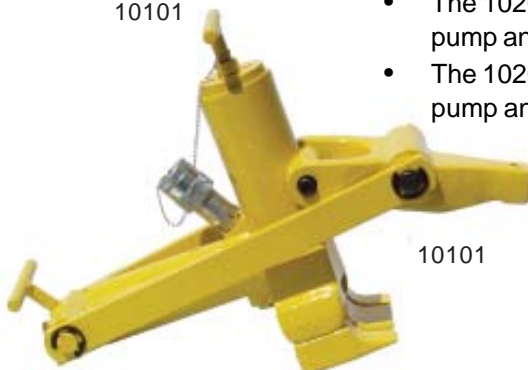

10101

Talon Bead Breaker



10109

- OTR Bead Breaker for heavy duty 3 piece rims that replace standard 5 piece rims.
- Works on both front and back of wheel without dismounting wheel from vehicle.
- Works on all new 3 piece 25" wheels or larger.
- Works on all wheels with CAT "Shur-Lok" safety feature.
- A MUST tool for all tire trucks.

Patent Pending



10109

"Maxi" Bead Breaker

- Newly redesigned bead breaker, works on **ALL** 3 piece wheels that replace older 5 piece wheels.
- Designed to work on front or back of wheel with no attachments or accessories.
- Clamps easily to wheel - no setup time.



Patent Pending



10102



Giant Tire/Earth Mover Bead Breakers

- Use on smaller 25" and 29" earth mover tire/wheel.
- 2-1/8" stroke, 10 ton ram easily breaks most beads.
- Compact design fits on backside of most wheels.
- 10205 kit contains 10105 bead breaker, 10500 pump, and 10604 hose assembly.
- 10206 kit contains 10105 bead breaker, 10590 pump, and 10604 hose assembly.



10105



10104

- Use on 5-piece rims 25" to 51" **without** pry bar/bead loosening pockets.
- Replaces Goodyear TO-100-HA.
- Model 10212 kit contains 10104 bead breaker, 10508 hand pump and 10604 hose assembly.



10104

- Use on all 39", 45", 51", 57" and 63" wheel sizes.
- In some cases you must first use model 10105 or 10100 bead breaker to start the movement of the rim flange. The 10103 can then be used.
- Model 10594 air/hydraulic pump recommended for operation.
- 10210 kit contains 10103 bead breaker, 10594 pump and 10602 hose assembly.
- Recently redesigned to accommodate all 63" wheels.



10103

Hydraulic Rams

- Used to break beads on back of 5 piece earth mover wheels.
- A "Must" for all earth mover tire trucks.
- Perfect for construction, heavy rigging and moving.
- New 25 Ton ram Model 10309 ideal for 51", 57" & 63" wheels.



Model 10305 shown.

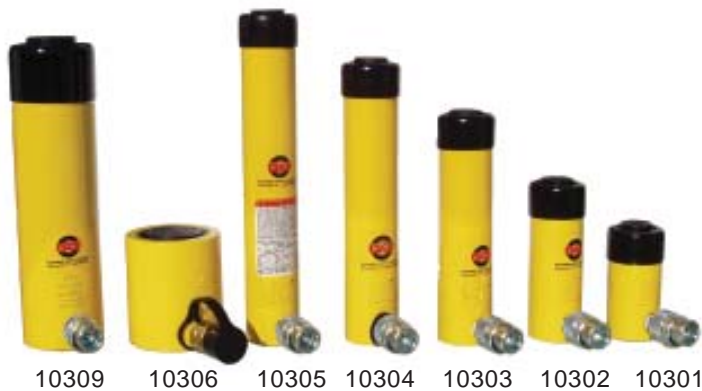

Specifications

Model	Capacity	Stroke	Retracted Hgt.	Model	Capacity	Stroke	Retracted Hgt.
10301	10 Ton	2-1/8"	4-3/4"	10305	10 Ton	10-1/8"	13-3/4"
10302	10 Ton	4"	6-3/4"	10306	30 Ton	2-7/16"	4-5/8"
10303	10 Ton	6-1/8"	9-3/4"	10309	25 Ton	8-1/4"	12-3/4"
10304	10 Ton	8"	11-3/4"				

Manual Bead Breaker

- Loosens tire bead from rim with leverage.
- Excellent for working on tire without removing the wheel from tractor.
- Will handle 38" and 42" 14-ply farm tractor and backhoe tires with drop center rims to small ATV and lawnmower tires.
- Operates with air ratchet wrench. **Do Not Use Air Impact Tool.**



70160



Dual Agricultural Tractor Tire Bead Breaker



10106

- Heavy duty 10 tons of force break the toughest beads.
- Breaks **inside** bead on **outside** dual farm tractor tires.
- Requires just 3" of operating space between dual tractor tires.
- No need to remove outside wheel to change tire on outside dual.
- Use with 10,000 psi air/hydraulic pump.



Compare ESCO model 10106 vs IMT-300

<u>Item</u>	<u>Ram Capacity</u>	<u>Distance when closed</u>	<u>Max. Width</u>
10106	10 Tons	3"	24"
IMT-300	4 Tons	4-1/2"	12"

Bead Push Off Tool



10108

- Lightweight tool for removing combine, forestry and tractor tires after breaking the bead.
- Has a pushing force of 8,000 lbs.
- Has a 5.5" stroke.
- A removable handle for compact storage and uses hydraulic pressure to force the tire off the rim.
- The push off tool hooks between the rim and the tire bead.
- Same as IMT-150.

Turbo II Air Hydraulic Pump 3.5 Quart Oil Capacity

- 3.5 Quart Oil Capacity
- Rugged polyglass reservoir with sight gauge.
- 10,000 p.s.i hydraulic pressure.
- Easily works on rams and bead breakers with oil to spare.
- Compact design easily fits storage bins.
- Fastest pump available.
- Shipped with premium hydraulic oil.



10500



10500

Air Hydraulic Pump 2.5 Quart Oil Capacity



10590

- High density 2 1/2 quart polyethylene reservoir.
- Same as OTC 4020.
- Lightweight.
- Air inlet filter keeps air clean.
- All metal air motor.
- 10,000 psi hydraulic pressure.

Air Hydraulic Pump 5 Quart Oil Capacity

- Rugged 5 quart metal reservoir.
- 10,000 psi hydraulic pressure.
- Specifically designed for tire service trucks.
- Air inlet filter keeps air clean.
- All metal air motor.



10592



10592



Turbo II Air Hydraulic Pump 5 Quart Oil Capacity



10502

- 5 Quart Oil Capacity
- Rugged polyglass reservoir with sight gauge.
- 10,000 p.s.i. hydraulic pressure.
- Low profile design, won't slip during use.
- Compact design easily fits truck storage bins.
- Fastest pump available.
- Shipped with premium hydraulic oil.

Air Hydraulic Pump 2 Gallon Oil Capacity



10594

- Rugged 2 gallon metal reservoir.
- 10,000 psi hydraulic pressure.
- Interior pump same as 10590 and 10592.
- Air inlet filter keeps air clean.
- All metal air motor.
- Maximum oil capacity for any application.

Hand Operated Pump 1 Quart Oil Capacity



10508

- 1 Quart Oil Capacity
- 10,000 p.s.i. hydraulic pressure.
- Shipped with premium hydraulic oil.

Hydraulic Hose

Hydraulic Hose with swivel fittings, hose won't kink. Reinforced with 2 layers of braided steel. Use with any 10,000 psi pump, ram and bead breaker.

10603 - 8 feet in length (3/8" x 3/8" male ends) . Includes coupler 10600.

10604 - 8 feet in length (3/8" x 3/8" male ends) . Includes hose half coupler only, model 10605

10610 - 8 feet in length (3/8" x 3/8" male ends) hose only.

10611 - 18 feet in length (3/8" x 3/8" male ends) hose only.



10603

Hy-Flo Couplers

- Hy-Flo Hydraulic Coupler. Includes ram and hose portions.
- Interchanges with OTC, Power Team, Enerpac and all ESCO hydraulic products.
- 10,000 psi rated.
- Components available separately.
- Ram (female) half model 10606, hose (male) half model 10605.



10600 Set

10606
Ram

10605
Hose

Quick Connects

10625 (Ram Half) Parker Coupler - Interchange with IMT tools. Quick connect style, 10,000 psi. rated.

10626 (Hose Half) Parker Coupler - Interchange with IMT tools. Quick connect style, 10,000 psi. rated.



10626 Hose

10625 Ram

Hydraulic Oil

10901- Premium Hydraulic Oil, 1 Gallon.

10902- Premium Hydraulic Oil, 1 Case (4 gallons).

Recommended replacement hydraulic oil for ALL ESCO tools.



10901



55 Ton/100 Ton Aluminum Jack



10300 in use

- Lightweight yet durable.
- For use with 10,000 psi pumps (see recommended list below).
- Ships completely assembled with valve, coupler and base.
- Perfect for off highway tire work.
- The preferred jack for road service.



10312



10308



10300

Specifications

Model	Weight	Collapsed Height	Extended Height	Weight Capacity	Recommended Pump
10312	29 lbs	10.5"	16.5"	55 Tons	10500, 10592
10308	38 lbs	11"	17"	55 Tons	10500, 10502
10300	40 lbs	11-3/4"	17-3/4"	100 Tons	10592

Crib Stand Set



12500 Set in use

- The crib stand set makes lifting easier.
- Included in the set are 3" - 6" - 9" heavy duty steel pieces that can be used individually or stacked together for various lift heights.
- All pieces interlock and will not slide or shift during lifting.
- For use with 55 Ton Jacks **ONLY**.
- Weight 120 lbs.



12503



12502



12501

(12500 Set)

Cribbing Blocks



12505
8 Block Set



12510
16 Block Set

A wide assortment of dry oak blocks in various sizes, lengths and widths to crib up vehicle in the field.

12505 - Truck and Agricultural set. - 8 block set.

Dimensions - (2 pcs.) 4" x 4" x 19", (2 pcs.) 6" x 6" x 19", (2 pcs.) 4" x 10",
(2 pcs.) 2" x 8" x 19" Weight 120 lb

12510 - Earthmover/OTR - 16 block set.

Dimensions - (2 pcs.) 4" x 4" x 19", (3 pcs.) 6" x 6" x 19", (3 pcs.) 8" x 8" x 19",
(3 pcs.) 4" x 10" x 19", (3 pcs.) 6" x 10" x 19", (2 pcs.) 2" x 8" x 19".
Weight 470 lbs

OTR Flange Ring Clamp

- Use crane to lift heavy side flanges on earthmover wheels with ease and precision.
- No more heavy manual lifting.
- Works on all wheels 24" thru 64" in diameter.
- Weight capacity 2000 lbs. or 1360 kg.
- No hooks needed.
- No more packing bead area with tire paste.
- 2 clamps can be used 180° apart with chain between them to pull rim flange out against the bead seat band to effect a seal on the o-ring.



90350 in use.



90350



Adjustable Locking Tire Sling



90100 in use

- Fast and easy way to handle tires in the horizontal or vertical position.
- Endless chain and locking device allows operator to position the tire as desired.
- Tire can be locked in any position For tire sizes up to 39".
- 6,500 lb capacity per chain at 60°.



90100

2 Way Push Bar Tool and Giant Tire Inflation Cage



90200

- Works from the end of the truck boom and is used to depress or push back the bead seat band and flange ring for fast and easy mounting and demounting of OTR/earth mover tires.
- Standard unit fits 25" through 51" rims.
- **Meets OSHA requirement and acts as a tire inflation cage when left in position during the inflation of earth mover tires.**



Flange Ring Puller



90300

- Designed to lift the rim base from the tire, remove the bead seat band from the tire, or aid in the seating of the bead seat band during inflation.
- Features 4-point chain hook assembly.
- Easily attached to the boom.
- 21,600 lbs capacity, 5,400 lbs capacity per chain.



Earth Mover Tire Bead Hook

- Three sizes.
- Fits all truck mounted tire cranes.
- Heavy duty, rugged construction.
- Contour of hook same as tire bead.
- Angle of tool won't allow tire to slip off when lifting.
- Prevents bead damage.

Available in 3 sizes:

90403	Light Duty - 4,000 lbs
90402	Medium Duty - 12,000 lbs
90401	Heavy Duty - 16,000 lbs



90403
Light Duty

90402
Medium Duty

90401
Heavy Duty

Calcium Chloride Pump

- Pumps 34 gallons of calcium chloride per minute.
- Newly designed valve will not leak.
- Unique polyvinyl material outlasts brass valves.
- Spring reinforced hoses for fill and evacuate.
- Comes complete with adapters for all valves (large bore and standard).
- Gauges are protected.
- Unit is portable or can be mounted in tire service trucks. Double diaphragm pump, 1 to 1 ratio.
- 10' hoses gives plenty of room to operate.
- USA made pump.
- Pump available with anodized aluminum valve model 10509M.



10509



10509



10515
Metal Valve



10513
Polymer Valve



10522
Calcium Chloride
Ejector Gun



22 Ton Air Hydraulic Jack



10414 in use

- Ideal for low profile, heavy duty lifting.
- Compact, low profile design allows for an easy fit between the wheels of tandem axle vehicle, saving time and labor.
- Air operated function enables quick lifting.
- Large diameter rubber wheels for easy movement.
- Carry handle improves portability.
- Self-returning spring minimizes operator's effort.
- Built-in filter reduces working noise.
- Single-piece handle.
- Manufactured to meet ASME/PALD safety guidelines.



10414

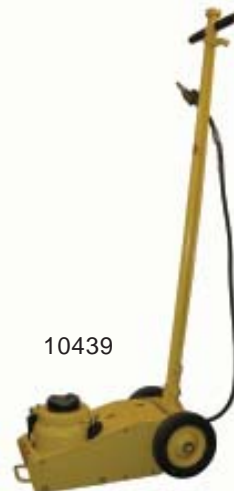

10439

Specifications

Model	Capacity	Handle Length	Min. Height	Max. Height	Weights
10414	22 Ton	43"	9"	18"	73 lbs.
10439	44 Ton	57-7/8"	9-1/4"	19-1/2"	135 lbs

20 Ton Jack Stand

- 10 Ton capacity for each stand.
- Jack has a four legged base for added stability.
- Support column has six different height positions, using pin to secure it.
- Units are sold as a pair.

Specifications

Capacity	Min. Height	Max. Height
20 Ton	17.5"	29.75"



10424

5 Ton/10 Ton Capacity Front End Lifter



10451

- Unit is designed to lift front or rear of vehicles.
 - Ideal for repair bay and service stations, for fast lifting and lowering of heavy duty trucks.
 - Features an automatic safety lock that engages in five different height positions independent of air pressure.
 - The lifting saddles are adjustable and can be raised and extended to desired position.
- Extra wide stance for extra stability.



10451

Specifications:

Model	10451	10452
Capacity	5 Ton	10 Ton
Air Pressure	175 psi.	200 psi.
Frame Width	45.25"	40.56"
Frame Depth	39"	35.69"
Overall Height	70.5"	66.13"
Lift Range	12.44"-47.38"	12.44"-49.63"
Saddle Width	39"-53.75"	35.5"-50.5"
Post Diameter	9.13"	12.81"
Weight	671 lb	774 lb

High Rise Floor Jack

- Designed for high axle vehicles, including construction and agricultural equipment.
- Chromed ram and dust seals prevent hydraulic contamination.
- Safety by-pass and overload system protect hydraulic block.
- High carbon steel chassis provide maximum strength in a light weight jack design.



10465

Specifications

Capacity	Max. Height	Min. Height	Overall Width	Handle Length	Shipping Weight
8 ton	35-7/8"	9-1/4"	18-3/4"	43-5/16"	312 lbs.



25 Ton Jack 2 Stage



- Designed for truck and bus workshops.
- Fits between dual rear wheels.
- 2 stage, 25/10 tons.
- Model 10401 (**Shown**) has telescoping handle, giving an extra 3 feet of reach.
- Precision European workmanship.

Specifications

Model 10405			
Lifting Capacity	25/10 ton	Raised Height Stage 1	10.8"
Weight	125 lbs.	Raised Height Stage 2	15"
Standard Extensions	(2)-3"	High Lift w/o adapters	15"
Low Height Stage 1	7.2"	High Lift w/adapters	19.3"

50 Ton Jack 2 Stage



- Lifts all Vehicles.
- 2 stages, 50/25 tons.
- Ideal for heavy duty truck and bus lifting.
- Model 10410 has telescoping handle, giving an extra 3 feet of reach.
- Precision European workmanship.

Specifications

Model 10402			
Lifting Capacity	50/25 ton	Raised Height Stage 1	13.5"
Weight	174 lbs.	Raised Height Stage 2	17.8"
Standard Extensions	(2)-3"	High Lift w/o adapters	15"
Low Height Stage 1	8.8"	High Lift w/adapters	21"

50 Ton Jack 3 Stage

- Extremely low minimum height (6").
- Easily lifts low buses as well as other low clearance vehicles.
- 3 stages, 50/25/10 tons.
- Model 10404 (**Shown**) has telescoping handle, giving an extra 3 feet of reach.
- Precision European workmanship.



Specifications

Model 10403

Lifting Capacity 50/25/10 ton

Weight 143 lbs.

Standard Extensions (2)-3"

Low Height Stage 1 6"

Raised Height Stage 1 8.4"

Raised Height Stage 2 13.3"

High Lift w/o adapters 13.3"

High Lift w/adapters 19.3"

25 Ton Jack 1 Stage

- For high axle vehicles.
- Ideal for tractors.
- Highest lifting height available.
- Model 10406 has telescoping handle, giving an extra 3 feet of reach.
- Precision European workmanship.



Specifications

Model 10400

Lifting Capacity 20ton

Weight 136 lbs.

Standard Extensions (2)-3"

Low Height Stage 1 14.4"

Raised Height Stage 1 24.4"

High Lift w/o adapters 24.4"

High Lift w/adapters 30.4"



Easy Way™ Tubeless Truck Tire Demounting System



70100

- Demount tubeless truck tires in seconds.
- Never lift tire to demount rear or bottom bead.
- Eliminates bead damage.
- Handles all tubeless truck tires 16.5" - 24.5" diameter and some super single "floats".
- No damage to aluminum or painted wheels.
- 30 day free trial.
- Demo video available on www.esco.net
- 70100 includes 70101, 70102 and 70103.

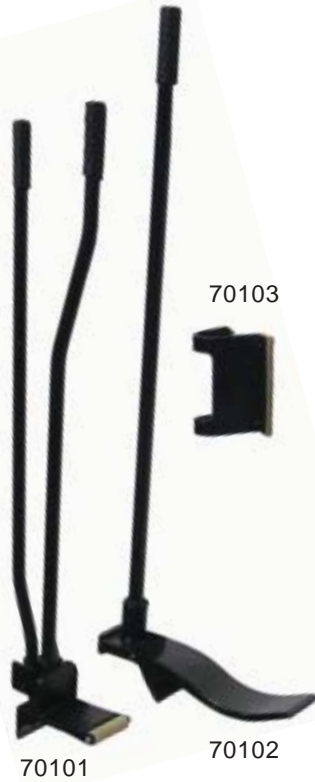

Slide Hammer



70150

- Breaks the most stubborn beads with ease.
- Reduces user fatigue with its spring action design.
- This design prevents slide hammer kick back.
- The wedge foot is forced between the bead and rim flange, delivering blow directly to the tip.
- Heavy duty tool, will not break.
- Compare with Ken Tool T26B.



Tire Lubricant

- Used by trucking companies, auto/truck original equipment manufactures and after market users.
- You may apply lubricant by hand with swab or sprayer model 70310.
- Environmentally safe.
- Model 70300 packaged 6 per case.



70300



70301

Sizes:	Weight:
Case (6-1 gallon)	60 pounds
55 Gallon	480 pounds

Sure Shot Sprayer

- Cuts lubricant cost by 75%.
- Eliminate wasted lubricant by spraying instead of pouring.
- Pressurize with shop air.
- Gets lubricant where you need it - onto the bead of the tire.
- Use with liquid lubricants.



70310

NuMag

- Nu-Mag is a balancing compound made from smooth durable microbeads.
- The microbeads will not stick to the inside of the tire.
- Nu-Mag will last the lifetime of the tire and can be reused in retreaded tires after the original tread has been worn off.



Model	Description	Pack	Model	Description	Pack
20450	2 oz bag	96 bags/case	20456	12 oz bag	24 bags/case
20451	3 oz bag	72 bags/case	20457	15 oz bag	24 bags/case
20452	4 oz bag	72 bags/case	20458	Applicator with gauge	
20453	6 oz bag	48 bags/case	20459	Replacement Filter	
20454	8 oz bag	48 bags/case	20460	Filtered Valve Core	200/case
20455	10 oz bag	36 bags/case			



Cyclone Tubeless Truck Tire Bead Seater



20380

- Perfectly balanced.
- Easy to operate.
- Lightweight (26 lbs.)
- Convenient support stand for floor storage.
- Easy to read air gauge.
- 5 gallon ASME rated tank.
- Easy to adjust nozzle.
- Butterfly valve releases air up to 50% faster than standard ball valves.
- Works on all tubeless tire sizes up through 24.5" heavy duty truck.
- Will even work on "Hard to seat" lawn, garden and golf cart tires.



Tubeless Bead Seater



20100 - 20204

- Helps seat difficult beads.
- One-piece rubber "O" rings that fits over the rim between the bead and the rim flange, making a seal which allows the tire to be inflated.
- Models available for both tubeless truck and passenger tires.
- 20100 for Passenger Rim Sizes 13" - 14"
- 20101 for Passenger Rim Sizes 14" - 15"
- 20200 for Truck Rim Sizes 16.5" - 17.5"
- 20202 for Truck Rim Size 19.5"
- 20204 for Truck Rim Sizes 22.5" - 24.5"



10 Ton Portable Air Lift Jack and Support Stand

- Lifting jack used for all trucks and agricultural tractors.
- Jack can also be used as a support stand to comply with OSHA when performing vehicle service.
- Two wheels make the jack easy to maneuver and position.
- Removable handle and air hose are equipped for remote operation and safe positioning.
- It is recommended to use in pairs.



10431

Specifications:

Capacity: 10 Ton Min. Height: 16.38" Max. Height: 49.25" Stroke: 10.88" Weight: 189 lbs

Hendrix™ BUDD Nut Wrench

- Eliminates frozen inner/outer cap nuts.
- Eliminates the need for hand and foot aid in separating the nuts, therefore reducing needless injury.
- Reduces the work and potential for back strain because there is no need to lay the tire down.
- Won't lose its grip on the outer cap nut so there is no loss of torque, which will give the impact wrench maximum power and efficiency.
- Won't slip or rotate out of position, significantly reducing the potential for damage to chrome and aluminum wheels.
- Locks onto rim.



60300



BUDD Nut Wrench

- Pork Chop Style - New design can't slip out of rim hole.
- Won't damage aluminum wheels.
- Holds outer cap nut securely.
- This new adaption of an old product solves the problem of damage to wheels as well as broken toes and injuries to the feet.
- All models have a replaceable polymer covered tail that locks the tool securely in place (model 60908)
- Available sizes: 1-1/2" (38 mm), 35 mm and 41 mm.



60301 - 60303



800-352-9852

www.esco.net

Page 22

Truck Wheel Dolly



70130



- Reduce back injuries in shop.
- Tire/wheel is rotated left or right on tiltable roller pads for perfect stud alignment.
- Perfect for 8-10 hole Budd type wheels.
- Removes tire/rim assembly fast and easy.
- Increases productivity.
- Saves time and money and maintenance free.
- Heavy duty tubular construction lifts 280 lbs.
- 3" caster/wheels roll the truck wheels for effortless removal or replacement. Works with tires 19.5" through 24.5"
- Use on standard size truck tire/wheel.

Super Single Wheel Dolly



70132

- Heavy duty wheel dolly designed specifically for super single and flotation tires.
- 14" wide rollers accommodate even the largest super single wheels.
- Lifting capacity of 450 lbs.

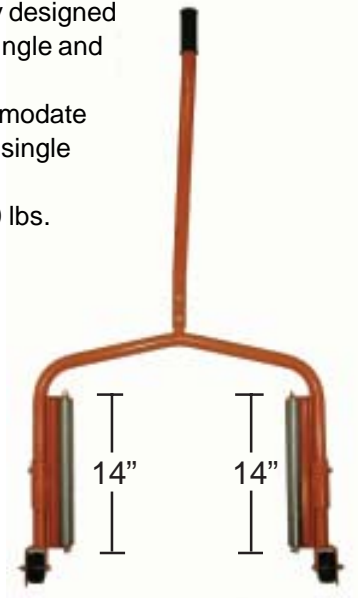

Brake Drum Dolly

- Engineered for removing, installing and transporting brake drum. It allows you to roll brake drum easily into service area.
- The lift height of the dolly can be adjusted from 10-1/4" to 15-1/2" so it may handle popular 15" and 16" brake drums.
- An ideal tool for removing, installation and transporting outboard mounted brake drums and indoor drums with disc wheel hubs.



70135



Specification

Low Lift Height 10-1/4"
High Lift Height 15-1/4"
Overall Length 62-1/2"

Wheel Diameter 8"
Shipping Weight 70.4 lbs.

High Rise Truck Wheel Dolly

- For removal and installation of single, dual and duplex tires/wheels/brake drums.
- Lifts-Tilts-Side Shifts & Rotates Tire/Wheel/Brake Drum assemblies.
- Side shifting for easy alignment of lug holes or brake drum.
- Heavy-duty rollers on lifting arms aid in realignment of bolt pattern.
- Tilting lift arm when fully loaded for additional stability.
- Two 360 degree swivel casters with caster lock.
- High gear ratio brake winch for easy one-handed lifting operation.



70131

Specifications:

Load Capacity: 1000 Lbs.

Overall Length: 46"

Max. Arm Tilt Angle: 28°

Min. Arm Elevation: 2"

Lifting Height: 39 5/8"

Overall Unit Height: 63 9/16"

Gross Weight: 352 Lbs.

Overall Width: 43 3/16"

Width Of Arm: 24 1/4"



E-Z Folding Tire Step



- Heavy duty, portable safety step.
- Easy way to service truck engine compartments.
- Hold up to 400 lbs.
- Folds for compact storage (less than 4").
- Galvanized heavy duty steel construction.
- Model 60202 for use with all Super Single Tire.



60202

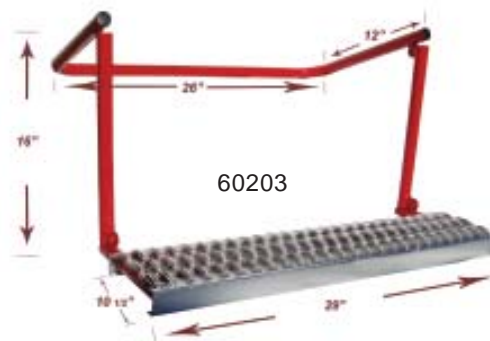

60203

"Tork-It" Truck Wheel Nut Torque Stick



60500-60509

- Fast accurate and inexpensive way to torque truck wheel nuts.
- Available from 175 ft. lbs. to 650 ft. lbs.
- Available in 3/4" and 1" drive.
- Customer uses existing sockets.
- Torque while tightening.



Available Sizes:

60500	3/4" - 475 ft lbs	60504	1" - 250 ft lbs	60508	1" - 650 ft lbs
60501	3/4" - 250 ft lbs	60505	1" - 350 ft lbs	60509	1" - 550 ft lbs
60502	3/4" - 175 ft lbs	60506	1" - 175 ft lbs		
60503	1" - 475 ft lbs	60507	3/4" - 350 ft lbs		

Truck Rim Protector

- Made of tough polypropylene material.
- Provides protection for aluminum truck wheels during mounting and demounting.
- Rope allows protector to be easily moved around rim during use.



70225

Truck Tire Bead Holder

- Keeps truck tire bead from slipping during mounting of top bead.
- Use 2 bead holders - no need to stand on tire to mount. Made from indestructible polymers.
- Will not scratch aluminum wheels.
- Great for hard to mount tire
- A must for all super singles



70140

Truck Tire Bead Holder

- Clamps securely to wheel to prevent tire from "walking."
- " Eliminates the use of vise-grips which damage wheels.
- For use with automatic tire changers and/or manual tire changing tools.



70215



Chrome Wheel Shield



50200

- Covers entire wheel while changing tires.
- Protects aluminum wheel surface from ground.
- Torque sequence imprint.
- Made of tough polymer.
- Yellow in color.
- Easily snaps into wheel, stays in place



Standard Chrome Wheel Protector



50301

- Protects aluminum, chrome and painted truck rims/ wheels during stud and nut removal.
- Inexpensive.
- Tough polymer material outlasts regular plastic.

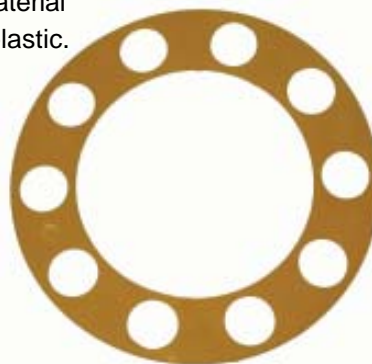

Deluxe Chrome Wheel Rim Protector



50303

- Extra tough material last up to 2 years.
- Will last up to 20 times longer than standard rim guards.
- Black in color.



Deluxe Chrome Nut Pliers

- Extra tough material will not wear out.
- No adjustment, fits all size chrome nut covers 1/2" to 1-7/8".
- Won't break or collapse.
- Best pliers in the industry.
- Use soft head to hammer nut covers onto nuts.



50100

Wheel/Nut Chamfer Wear Gauge

- Disc wheel measuring tool kit shows you when wheel and inner and outer cap nuts are worn out.
- Provides a guide to visually detect excessive wear in .875R spherical chamfers of bolt holes in disc wheels.
- Designed for use with stud piloted steel wheels which have .875 spherical bolt holes 3/8" to 1/2" disc thickness.
- Use only with Stud Piloted Steel Wheels.



60929



Truck Wheel Guard

- Prevents rust, scale, corrosion and galvanic electrolysis on disc wheels.
- Nylon separator plate, placed between the hub or drum and the wheel, and/or between two wheels on dual applications.
- The wheel-guard is highly recommended in severe applications where corrosion and/or wear has been identified as a problem.
- Both aluminum and steel wheels can benefit from wheel-guard.



60100 - 60108

Model	Application	Wheel Type
60100	1-1/8" and 7/8" diameter studs, 10-hole, 11-1/4" B.C.	Stud Pilot
60101	3/4" diameter studs, 10-hole, 11-1/4" B.C.	Stud Pilot
60102	22 mm diameter studs, 10-hole, 285.75 mm B.C.	Hub Pilot
60104	22 mm diameter studs, 10-hole, 335 mm B.C.	Hub Pilot
60105	20 mm diameter studs, 8-hole, 275 mm B.C.	Hub Pilot
60106	5/8" studs, 8-hole, 6-1/2" and 170mm B.C., 4.82" ID, GM & Dodge	Hub Pilot
60107	5/8" studs, 8-hole, 6-1/2" and 170mm B.C., 5.25" ID, Oval Holes, Ford	Hub Pilot
60108	5/8" studs, 8-hole, 255mm B.C., 6.25" ID, Locating Holes, Ford	Hub Pilot



Rimlock Wheel Clamps



960 (80100)



961 (80101)

- Models 960 and 961
- For Cast Spoke Wheels.
- Designed to replace original equipment clamps on steering axle, single rear axle, and cast spoke wheels using multipiece demountable rim.
- Makes it virtually impossible for the lock-ring to separate from the rim.
- Reduces the problem of losing a tire or lock-ring during sudden tire deflation while driving.
- Tires can now be inflated without removing the rim from the vehicle.
- Recommended for trash haulers using tubeless tires and demountable cast spoke Dayton-type rims on steering axles.

“Wheelok™” Wheel Locking System



80200 -80222

- Available for all model wheels (hub piloted , stud piloted and cast spoke)
- Prevents theft of truck tires, rims and wheels.
- Customized key fits only your lock.
- For all light and heavy duty trucks.
- Effective, secure, economical.
- Round nut and sleeve can't be gripped by ordinary lug wrench or even a pipe wrench.
- See price sheet for part numbers.
- Protect one truck or entire fleet with same key combination.



Bushing/Seal Tool Kit



40320

- Used for removal and installation of Brake Camshaft Bushings and seals, brake anchor pin bushings, front/steer axle king pin bushings.
- Kit contains 4 cylinders and 8 washers designed to fit the most popular sizes of bushings and seals.
- Works on all brake manufactures systems.
- Eaton-Rockwell-Spicer-Dana-Standard Forge etc.
- Quick and easy to use.
- Eliminates damage to parts during installation.

King Pin Cap Removal Tool

- Removes King Pin Caps on Mack Trucks with ease.
- Clears threads on axle casting.
- Impact rated (removal tool only, thread chasers cannot be used with impact wrench).
- Greatly improves the removal and installation of the thrust bearing adjustment screws on 10,500 lbs., 16,000 lbs., and 20,000 lbs. axles.
- Kit includes large and small thread chasers for clearing the cap threads on the axle casting.



40121

Rib Nut Stud Remover Kit

- For removing damaged 1-1/8" Disc wheel inner cap nuts, 3/4" lug studs and 5/8" lug studs.
- Model 40100 - Complete stud remover kit.
- Model 40103 - Removes damaged 1-1/8" Disc inner cap nuts.



40100

Rib Nut Stud Remover

Model Application

- 40105 Removes damaged 3/4" lug studs.
- 40106 Removes damaged 5/8" lug studs.
- 40107 Removes damaged 1-1/8" BUDD wheel inner caps.
- 40110 For 17 mm inner cap nuts.
- 40112 For 21 mm inner cap nuts.



40105-07



Oil Filter Crusher



10920

- Reduces filter size by 75% and removes over 95% of residual oil.
- Crushes forklift, automotive and truck oil filters in seconds.
- Compact size takes less than four square feet of floor space.
- Easy to operate, load the filter and close the door to activate the crushing cycle.
- Operates unattended, safety switch prevents operation when door is open.
- Specially designed door channel prevents drips and leakage, keeping oil in the chamber and not on the floor.
- One year limited warranty.
- Stand, hose, filter, regulator and drain hose included with unit.

Specifications:

Height: 28 1/2"	Max. Filter Height:	7 1/2"
Width: 12 3/4"	Filter Diameter:	6"
Depth: 12 3/4"	Crushing Force:	10 tons
Weight: 100 lbs.	Pump/type:	Air Hydraulic

Air Hose Reel



60800 - 60801

- Compact space saver.
- Designed to handle general air and water applications.
- 1/4" steel mounting plate.
- Multiposition ratchet lock.
- Premium quality with Economy price.
- Lightweight and heavy duty.

Specifications:

Model	Max. Working Pressure	Male Air Inlet	Max. Hose I.D.	Max. Hose Length
60800	300 psi	1/4"	3/8"	50 ft.
60801	300 psi	1/2"	1/2"	50 ft.

Air Bags



12105



12107



12109



12112



12113

- Maximum Force Air Bags
- The air lifting bag is a reinforced, molded inflatable jack. Airbags can be positioned in tight or confined spaces with as little as one inch clearance.
- Lifting capability when inflated is from 13 to 70 tons.
- The airbags are made up of Kevlar aramid fiber consisting of five layers.
- Airbags may be used for lifting in several different industries such as, construction, manufactured homes, house moving, mining, military, railroad and fire/rescue.

Airbags are available in different sizes. See below:

Model #	Material	Weight	Lift Capacity	Max. Lift Capacity	Dimensions	Lift Height at Max. Inflation
12105	Kevlar	10 lbs	13 tons	13.5 tons	15" x 15" x 1"	7.5"
12107	Kevlar	17 lbs	22 tons	22.5 tons	20" x 20" x 1"	9"
12109	Kevlar	24 lbs	32 tons	31.5 tons	21" x 25" x 1"	11"
12112	Kevlar	45 lbs	50 tons	50.1 tons	29" x 29" x 1"	15"
12113	Kevlar	52 lbs	70 tons	69.36 tons	34" x 34" x 1"	18"

12119



12119 - Single Safety Relief and Control Valve.

12123



12122 - Air Hose, 16ft, Red

12123 - Industrial Nipple with Valve.



12122



Lightweight Forklift Jack



10435

- Perfect for shop or van.
- Lightweight ... 68 lbs.
- Meets ANSI/CE Standards.
- 2 1/4" low clearance.
- Lift height 16 1/4".
- Removable handle.
- Very compact.
- 1-year warranty

Specifications

Capacity	8,800 Lbs.	Net Width	8"
Lifting Height Min.	2 1/4"	Weight	68 Lbs.
Lifting Height Max.	16 1/4"		

7.5 Ton Forklift Jack



10437

- The solution for heavy duty forklifts.
- Easily handles larger lift trucks found in heavy industrial shops.
- 15,000 pound lifting capacity.
- Ultra low lifting height of 2-1/4".
- Jack moves easily throughout the shop.

Specifications:

Lifting Capacity	15,000lbs
Min. Starting Height	2-1/4"
Shipping Weight	99lbs
Max. Lifting Height	16-1/2"
Width	9"

Fork Lift Jack Stands



10436

- Designed for forklift trucks.
- Work on all vehicles.
- 20,000 lb. capacity per pair.
- Rugged steel construction.
- Adjust range low 9 1/2", high 16".
- Safety lock ring on adjustment pin.
- Priced and sold as a set.

Mag/Chrome/Alloy Wheel Mount/Demount

- Eliminates damage to mag, chrome and alloy wheels.
- Fits all center post tire changers.
- Replaceable polymer inserts get 500 to 700 mounts/demounts when used correctly.
- Eliminates "booties" that slip off "combo" tool.
- Change inserts in seconds.
- Not for use on steel wheels.
- Shipped complete with one set of replacement polymer inserts.

70201 Kit



70200

Mount/Demount Booties

- For use with any center post combination mount/demount tool.
- Protects alloy and chrome wheels from being damaged during use of the mount/demount tool.

70221 - Large White Bootie

70222 - Small White Bootie

70223 - Bootie Kit - Contains
(10) 70222 and (10) 70221



70221 - 70223

Lube Bucket

70901

Angled Lube Bucket - Designed to fit Coats 4040, 4040SA and 4050 tire changers.



70901

70904

Straight Lube Bucket - Designed to fit Coats RC 15, 20, 5060 and 5070 tire changers.



70904

Lubricant Swab

70902

Swab - 14-1/2" - Absorbent swab used to lubricate beads for tire changing.



70902

70903

Swab - 11-1/2" - Absorbent swab used to lubricate beads for tire changing.

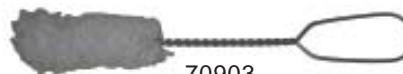

70903



No-Mar Valve Stem Remover & Installer



50103

- Will not mar or scratch expensive chrome and alloy wheels.
- Made of composite plastic materials.
- Install and remove tubeless valves in seconds.
- Easy to use.
- Won't bend or break.
- Long lasting.
- Metal tip helps push out old snap in valve.

Valve Stem Puller, Plastic



50107

- Plastic screw on type.
- Will not scratch or mar aluminum wheels.
- Durable plastic has long life.
- Model 50117 has metal rod inserted for extra strength.
- Metal rod will not break.



50117

Valve Stem Puller



50108

- Screw on type.
- Will not break.
- Works for all styles of valves.
- Straight design.
- Ridges allow tool to work against any rim.

Heavy Duty Valve Stem Puller



50112

- Plastic screw on type.
- Will not scratch or mar aluminum wheels.
- Durable plastic has long life.
- Super thick plastic will not break.

Valve Stem Puller Steel

- Bent design for easier access of all valves.
- Screw on type.
- Will not break.
- Works for all styles of valves.
- Ridges allow tool to fit perfectly onto rim.



50109

Valve Stem Installer

- Heavy Duty polymer coating lasts for thousands of uses.
- Snap-in valve mounting tool.
- Bent design for easier access of all valves.



50114

Valve Stem Installer

- Rubber sleeve protects chrome wheels.
- Snap-in valve mounting tool.
- Easily pulls the snap-ins to be seated.



50113

Valve Core Screw Driver Combi

- One side fits standard bore and the other side fits large bore.
- Tool head swivels so valve core can easily be removed with one hand.
- Includes pocket clip.



50115



Wheel Weight Plier, Standard



50110

- Black powder coated finish.
- Red PVC coated handles.
- Premium quality, economy price.

Wheel Weight Plier, Nickel



50120

- Deluxe unit
- Drop forged chrome vanadium steel
- Nickel chrome plated.
- Red PVC coated handles.

Wheel Weight Plier, Soft Head



50121

- Deluxe unit.
- Soft head will not damage aluminum or mag wheels. Nickel chrome plated.
- Red PVC coated handles.

Wheel Weight Plier, Powdered Coated



50130

- Deluxe unit.
- Drop forged chrome vanadium steel.
- Black powder coated.
- Red PVC coated handles.

Wheel Weight Hammer

- Passenger Wheel Weight Hammer.
- Drop forged chrome vanadium steel.
- Hardened and tempered for longer life.
- Red coated handle fully cover plier....no sharp edges.



50122

Wheel Weight Plier, Truck

- Black finish, Red PVC coated handle.
- Heavy-duty plier ideal for hammering truck wheel weights.



50140

Wheel Weight Hammer

- Soft head wheel weight hammer is ideal for hammering coated wheel weights.
- Claw hook is replaceable, model 50147H.



50147



Tire Mounting Clamp



70210

- For European style rim clamp tire changers.
- Acts like third and fourth hand.
- Clamp holds tire bead in drop center. Clamps quickly to rim, won't allow tire to "walk".
- Plastic, will not mar or scratch decorative or aluminum rims.



Tire Lever 20" & Tire Lever 24"



70211 (20")



70212 (24")

- Bead lifting tool for all rim clamp tire changers.
- Designed for ease of lifting the bead during tire changing.
- For use with automatic tire changing machines.

Tire Lever Boots



70220

- Made of tough polypropylene material.
- Protects light metal rims from being scratched during mounting and demounting.
- Used with Tire Levers model 70211 or 70212.

Rim Width Calliper

- For use with all tire balancers.
- Durable and lightweight.
- The measuring scale are designed into the mold for long life.
- Easy to read.



50150

Wheel Gauge

- Measures pitch circle diameter of wheels.
- Measures wheel bolt patterns domestic and import.
- Made of durable polypropylene.
- Wheel gauge measure both steel and aluminum wheels.



50155

Wheel Gauge

- Stop custom order and replacement order errors by using the Wheel Gauge to measure bolt patterns.
- Match up those loose custom and stock wheels using Wheel Gauge.
- Wheel Gauge is divided into different colors.
- Measurements are molded onto gauge for easy reading.



60925

Adhesive Weight Remover

- Made of tough polyurethane material.
- Glass filled for good strength and durability.
- Used for scraping adhesive wheel weights.
- Excellent for removing pin stripes.
- Won't scratch any surface.



50146



Sav-A-Stud Plus, Sav-A-Stud Plus H/D, Spindle Saver

- Restore Don't Replace.
- The best way to fix damaged threads.
- A 30-second solution to an hour-long job.
- Repairs wheel studs, spindles and standard threaded studs.
- Damaged studs can be renewed in minutes without removing the caliper, rotor, or stud.
- Unique, patented hinged design (instead of two separate halves).
- Every shop needs them.
- Lifetime guarantee.
- Unit comes complete in a plastic carrying case.

Model	Sizes
30120	7/16" - 20, 1/2" - 20, 9/16" - 18, 5/8" - 18, 12mm - 1.25, 12mm - 1.50, 12mm - 1.75, 14mm - 1.50.
30125	3/4" - 16" Right, 3/4" - 16" Left, 22 x 1.5mm
30135	13/16"x20, 27/32"x20, 7/8"x14, 1"x14, 22mmx1.0, 22mmx1.50, 24mmx1.50, 24mmx2.0, 25mmx1.50, 27mmx2.0, 11/16"x24, 3/4"x16, 3/4"x20, 16mmx1.0, 16mmx1.50, 18mmx1.50, 19mmx1.50, 20mmx1.0, 20mmx1.25, 20mmx1.50



30120

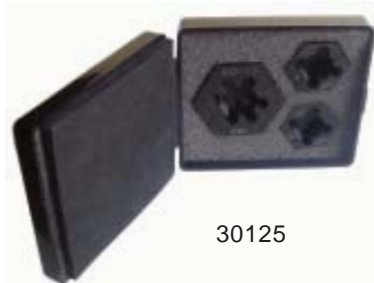

30125



30135



Sav-A-Stud Rethreader

- A 30-second solution to an hour-long job.
- Solves the Problem of Removing and Replacing Damaged Wheel Studs.
- Today's complex disc brake, four wheel drive and front wheel drive vehicles make replacing damaged wheel studs a costly job, which frequently must be absorbed.
- If the rotor becomes bent or warped during stud replacement, then it must be turned; and if you turn one rotor, the other should be done also.
- Damaged studs can be renewed in minutes without removing the caliper, rotor, or stud.
- Lifetime guarantee.
- Metric Kit Model 30300 available.
- Individual sizes available - see price sheet.
- Original Sav-A-Stud Rethread Kit.



30100

Sizes : 7/16", 1/2", 9/16", 5/8", 12mm 1.25, 12mm 1.5, 14mm 1.5, 1/2" SAE Left.

Repair Program

GUARANTEED 1 Day Turnaround Service.
We Receive 1 Day-Repair-Ship Back To You Next Day



- ESCO will have UPS pick at your location.
- ESCO will guarantee our work for 30 days.
- ESCO has rental tools available.
- ESCO repairs IMT-FEC-Stellar-Blackhawk-OTC-Power Team & Enerpac hydraulic pumps, bead breaker and cylinders.
- ESCO tech staff may be able to solve your problem over the phone.



800-352-9852

www.esco.net

Page 42