



Single Speed Hydraulic Air Pumps

Model: ZAP-101

Air Pressure Range: 40-140 psi (3-10 bar)

Shop air supply relief valve.

Settings: Up to 10,000 psi (700 bar)



Usage

When connected to your shop air lines, these versatile pumps can safely deliver up to 10,000 psi (700 bar) of hydraulic pressure to cylinders, small presses, and hydraulic tools for lifting, crimping, pipe cutting, pulling, and many other applications.

Special Features

1. Beats the leading competitors in oil flow delivery by as much as two to one, doing more work in less time.
2. Portable to any job site equipped with compressed air. Takes the place of manual pumps. Less operator fatigue, more productivity.
3. Plenty of oil to power cylinders up to 55 ton capacity.
4. Compact, lightweight design for easy handling and storage.
5. Internal relief valve protects system components.
6. Metal housing is extremely heavy-duty, these pumps are durable and long lasting.
7. 2-stage release mechanism for fast return while reducing hydraulic shock. Operates easily by hand or foot.
8. All-metal air motor for reliability and easy maintenance.
9. Operates at up to 10,000 psi (700 bar).



Optional aluminum reservoir with plastic see-through window.



Optional see-through reservoir for easy oil level monitoring.

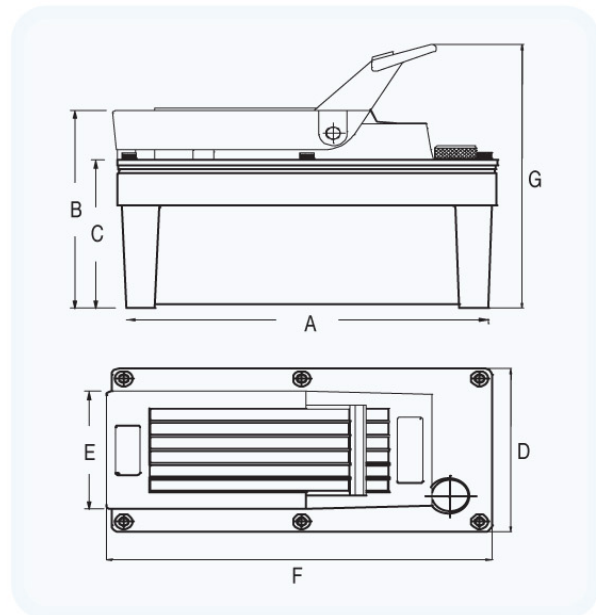
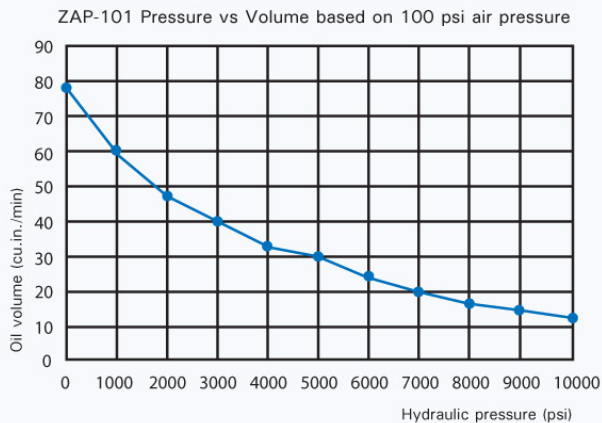

Model #	Oil Capacity (in ³)	Pressure Rating (psi)	Output Flow Rate (in ³ /min.)		Air Press. Range (psi)	Dimensions (in)							Oil Port (in)	Ship Weight (lbs)
			No Load	Load		A	B	C	D	E	F	G		
ZAP-101	98	10000	77	13	40 - 140	8.05	6.04	4.53	9.53	9.36	4.36	3.56	3/8" NPT	21
ZAP-101P	98	10000	77	13	40 - 140	8.05	6.04	4.53	9.53	9.36	4.36	3.56	3/8" NPT	21

P=Plastic tank